

60" CAST IRON ROLL TOP TUB

Cat. No.
CTRN60



L: 60 3/4"
W: 30 1/2"
H: 23 1/4" (from floor to top of tub)
18 5/8" (from bottom of tub to top of tub)

The following is recommended for CTRN60 tubs without faucet holes:

- Faucets: part #4602
- Rigid, freestanding supplies: part #4502
- Leg tub drain: part #5599

Gallon Capacity: 40
Shipping Weight: 500 lbs.
Empty Weight: 287 lbs.
Filled Weight: 622 lbs.

Features:

- ▶ Inside finish is white enamel
- ▶ Ball and claw feet available in 6 finishes or unfinished
- ▶ Tub exterior is white (epoxy)
- ▶ No faucet holes
- ▶ Non-skid strips
- ▶ Feet are attached and leveled before shipment
- ▶ Tub is thoroughly inspected before shipment
- ▶ Cast iron base available: part# **CIBR60**

Foot Finishes:

- BP** Polished Brass
- CP** Polished Chrome
- PN** Polished Nickel
- SN** Brushed Nickel
- WH** White
- ORB** Oil-rubbed Bronze

Meets or exceeds the following specifications: A112-19-1M 1994.

Extra Paint Charge (inside of tub is always white enamel):

Bisque Paint - \$160

Black Paint - \$160

Bathtubs painted in bisque or black are considered "special order" and are not returnable.

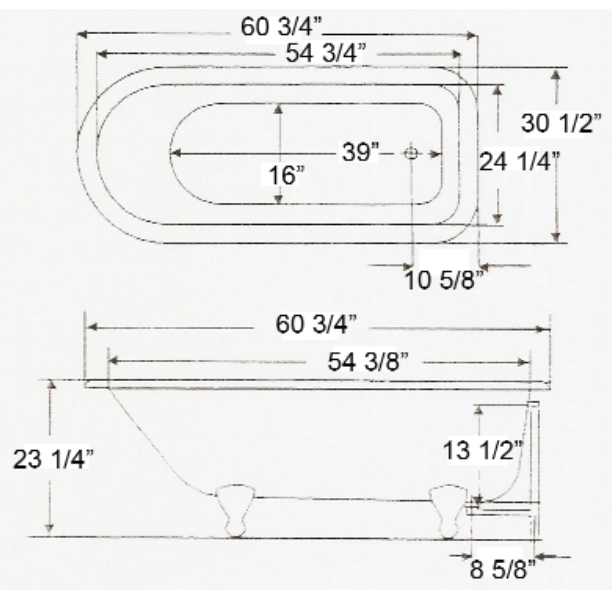

Dimensions of fixture are nominal and may vary within the range of tolerances established by ANSI Standard A112.19.2. Dimensions and specifications subject to change without notice.