

71" CAST IRON DOUBLE SLIPPER TUB

Cat. No.
CTDSN



L: 71"
W: 30 1/2"
H: 30" (from floor to top of tub)
22" (from floor to lowest tub rim)
18 1/2" (from bottom of tub to top center of tub)
26 3/4" (from bottom of tub to top of tub)

Toe to Toe Measurements:

35" Front to back
20-1/2" Side to side

The following is recommended for CTDSN tubs without faucet holes:

- Faucets: part #4602
- Rigid, freestanding supplies: part #4502
- Leg tub drain: part #5599

Gallon Capacity: 43 1/2
Shipping Weight: 544 lbs.
Empty Weight: 364 lbs.
Filled Weight: 728 lbs

Features:

- ▶ Inside finish is white enamel
- ▶ Lion feet available in 6 finishes
- ▶ Tub exterior is white
- ▶ No faucet holes
- ▶ Non-skid strips
- ▶ Feet are attached and leveled before shipment
- ▶ Tub is thoroughly inspected before shipment
- ▶ Cast iron base available: part# **CIDRB**

Extra Paint Charge (inside of tub is always white enamel):

Bisque Paint - \$160 **Black Paint** - \$160
Bathtubs painted in bisque or black are considered "special order" and are not returnable.

Foot Finishes:

BP Polished Brass **SN** Brushed Nickel
CP Polished Chrome **WH** White
PN Polished Nickel **ORB** Oil-rubbed Bronze

.....
: Meets or exceeds the following :
: specifications: A112-19-1M 1994. :
.....

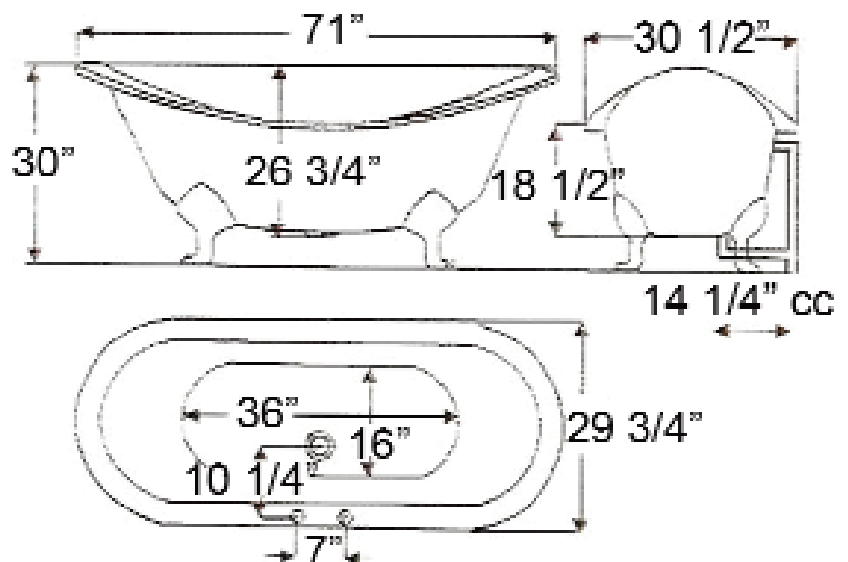

Dimensions of fixture are nominal and may vary within the range of tolerances established by ANSI Standard A112.19.2. Dimensions and specifications subject to change without notice.