

**MOZART  
ACRYLIC DOUBLE  
SLIPPER TUB**

Cat. No.  
ATDSN75B



L: 75"  
W: 38 1/4"  
H: 28 1/2"

Water depth to top of tub: 15 1/2"

**The following is recommended for ATDSN tubs:**

- Faucets: part #7082 or #7088
- Use with Freestanding Bath Supplies: part #4502-PL
- Leg tub drain: part #5599LT or #5599TS

Gallon Capacity: 100  
Shipping Weight: 300 lbs.  
Empty Weight: 120 lbs.  
Filled Weight: 955 lbs.

**Features:**

- ▶ Interior and exterior walls 4mm acrylic sheets
- ▶ Air between walls acts as insulator
- ▶ No overflow
- ▶ No faucet holes
- ▶ Base included
- ▶ Tub is thoroughly inspected before shipment

**Tub Colors:**

**WH** White

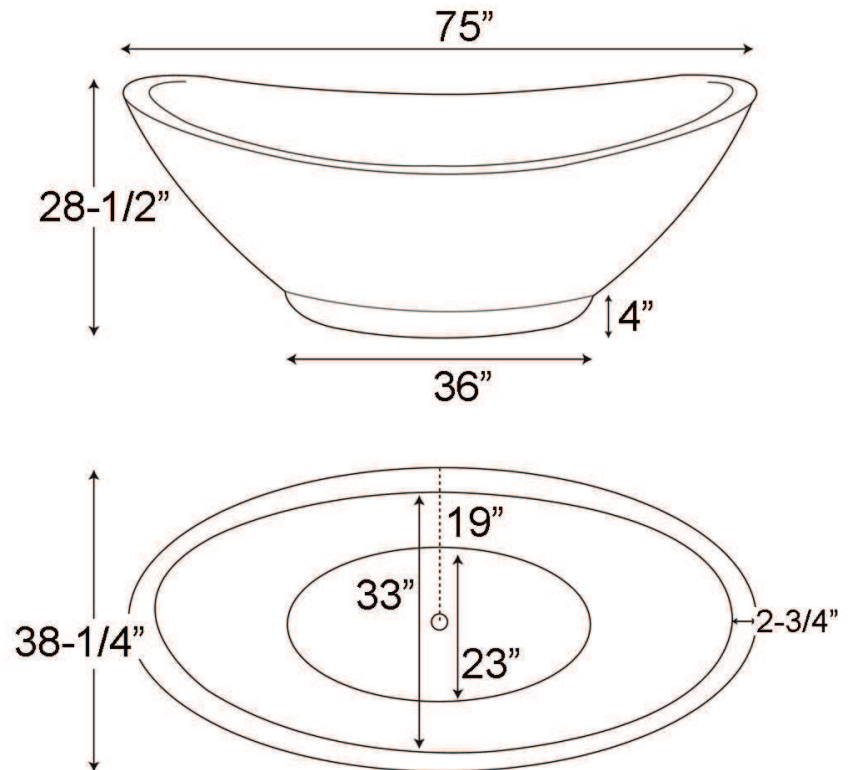

Dimensions of fixture are nominal and specifications subject to change without notice.