

DOUBLE ACRYLIC SLIPPER TUB

Cat. No.
ADTS60



L: 60"
W: 30"
H: 22 1/2" (from floor) short end
32" (from floor) tall end

**The following is recommended for
ATS60 slipper tubs:**

- Faucets: part #4602, #4022, or #4025
- Use with Freestanding Bath Supplies:
part #4502-PL
- Leg tub drain: part #5599

Gallon Capacity: 33
Shipping Weight: 120 lbs.
Empty Weight: 100 lbs.
Filled Weight: 611 lbs.

All ATS60 tubs have no faucet holes.

Features:

- ▶ Inside finish is either white or bisque to match outside color
- ▶ Ball and Claw Feet available in 8 finishes
- ▶ Smooth acrylic surface inside and out
- ▶ Tubs ship with feet attached and leveled
- ▶ Tubs are thoroughly inspected before shipment

Tub Colors:

WH White
BQ Bisque

Foot Finishes:

BP Polished Brass	PN Polished Nickel
CP Polished Chrome	BQ Bisque
BN Brushed Nickel	BL Black
ORB Oil Rubbed Bronze	WH White

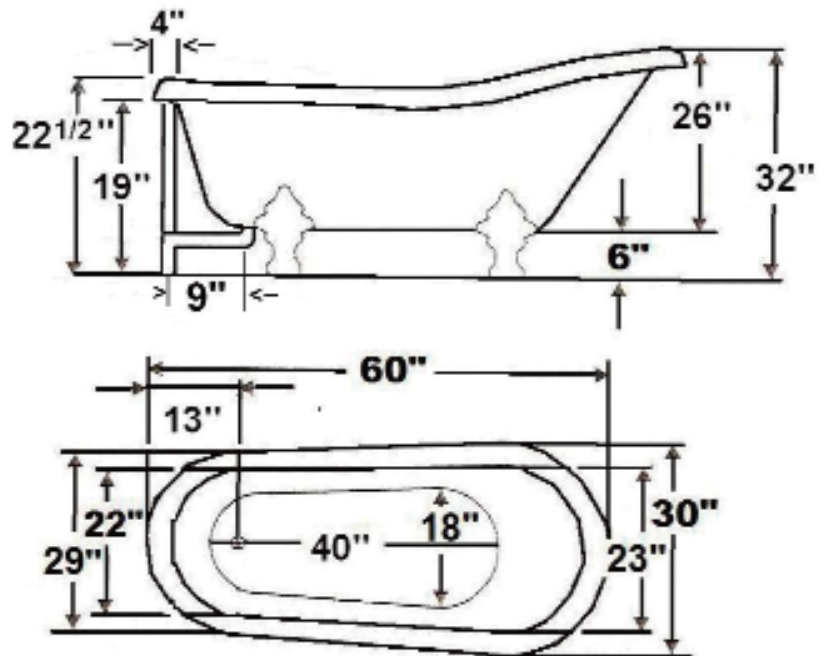

Dimensions are nominal and specifications subject to change without notice.