

DOUBLE ACRYLIC ROLL TOP TUB

Cat. No.
ADTR60

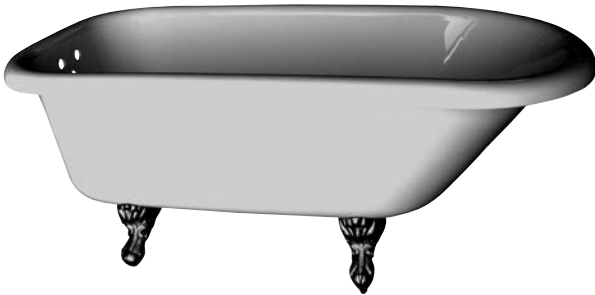

L: 60 1/2"
W: 29 1/2"
H: 23" (from floor)
18" (from bottom of tub)

**The following is recommended for
ADTR60 tubs**

- Tub wall-mounted faucets
- Double offset bath supplies: **Part# 5576**
- Leg tub drain: **Part# 5599**

Do not use with rigid, freestanding supplies

Gallon Capacity: 40
Shipping Weight: 110 lbs.
Empty Weight: 90 lbs.
Filled Weight: 410 lbs.

All ATR60 tubs have 3 3/8" centers in tub wall.

Features:

- ▶ Inside finish is either White or Bisque to match outside color
- ▶ Ball and Claw Feet available in 8 finishes
- ▶ Smooth acrylic surface inside and out
- ▶ Tubs ship with feet attached and leveled
- ▶ Tubs thoroughly inspected before shipment

Tub Colors

WH White
BQ Bisque

Foot Finishes

BP Polished Brass	PN Polished Nickel
CP Polished Chrome	BQ Bisque
BN Brushed Nickel	BL Black
ORB Oil Rubbed Bronze	WH White

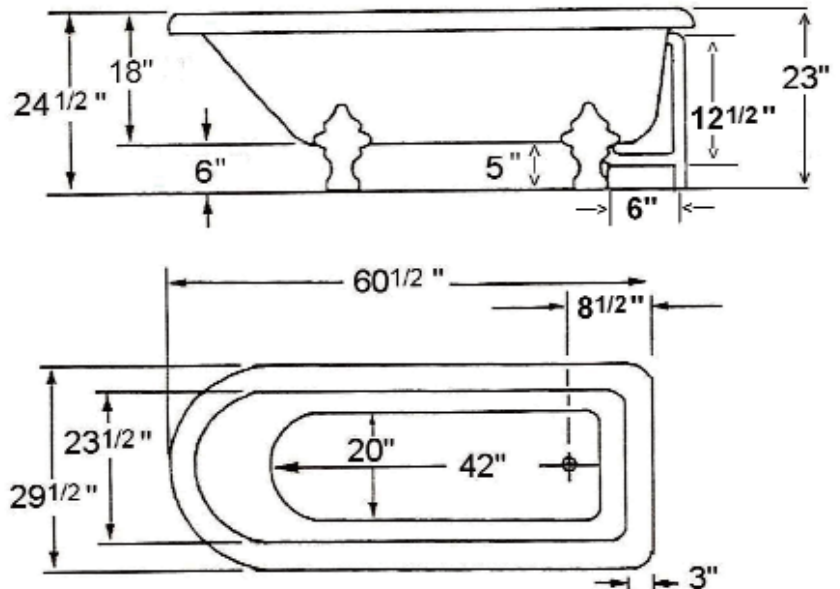

Dimensions are nominal and specifications subject to change without notice.